



EDI Guide

## **Remittance Advice (INVOIC)**

**Electronic Data Interchange for Furniture**

based on  
**EANCOM 2012**

Version: 1.0.1  
Variant: DCC-FURN  
Published: 13.01.2023  
Author: Integrated Worlds

---

## Contact

Daten Competence Center e. V.  
Dr.-Ing. Olaf Plümer  
Geschäftsführer  
Goebenstraße 4-10  
32052 Herford  
Tel.: +49 52 21 / 12 65 37  
Fax.: +49 52 21 / 12 65 5 37

E-Mail: [pluemer@dcc-moebel.org](mailto:pluemer@dcc-moebel.org)  
Info: [www.dcc-moebel.org](http://www.dcc-moebel.org)



**Daten  
Competence  
Center e. V.**

## Table of Contents

1 Structure.....	3
2 Diagram .....	4
3 Segments .....	9
4 Examples.....	39

## Document Structure

Index	No.	Tag	St	MaxWdh	Level	Description
0000	1	<a href="#">UNA</a>	C	1	0	Service string advice
0000	2	<a href="#">UNB</a>	M	1	0	Interchange header
<b>Message header</b>						
0010	3	<a href="#">UNH</a>	M	1	0	Message header
0020	4	<a href="#">BGM</a>	M	1	0	Document type and document number
0030	5	<a href="#">DTM</a>	M	1	1	Document date
0030	6	<a href="#">DTM</a>	M	1	1	Execution date
0040	7	<a href="#">RFF</a>	C	5	1	Payment instruction number
0050	8	<a href="#">FII</a>	C	1	1	Credit institution of the recipient
0050	9	<a href="#">FII</a>	C	1	1	Credit institution of the payer
0060	10	<a href="#">PAI</a>	C	1	0	Payment instructions
0090		<b>SG1</b>	R	99	1	Names and addresses of the parties involved
0100	11	<a href="#">NAD</a>	M	1	1	Name and address
0170		<b>SG4</b>	C	5	1	Currency
0180	12	<a href="#">CUX</a>	M	1	1	Currencies
0200		<b>SG5</b>	C	999999	1	Documents
0210	13	<a href="#">DOC</a>	M	1	1	Document/message details
0220	14	<a href="#">MOA</a>	M	5	2	Invoice amount
0220	15	<a href="#">MOA</a>	M	5	2	Regulation amount
0220	16	<a href="#">MOA</a>	M	5	2	Tax amount
0220	17	<a href="#">MOA</a>	M	5	2	Correction amount
0240	18	<a href="#">RFF</a>	C	5	2	Reference
0290		<b>SG7</b>	C	100	2	Amount corrections
0300	19	<a href="#">AJT</a>	M	1	2	Adjustment details
0310	20	<a href="#">MOA</a>	C	1	3	Correction amount
0320	21	<a href="#">RFF</a>	C	1	3	Reference
0350		<b>SG8</b>	C	9	3	Tax
0360	22	<a href="#">TAX</a>	M	1	3	Duty/tax/fee details
0370	23	<a href="#">MOA</a>	C	9	4	Monetary amount
0570	24	<a href="#">UNS</a>	M	1	0	Section control
0580	25	<a href="#">MOA</a>	M	99	1	Total amount
0580	26	<a href="#">MOA</a>	M	99	1	Regulated amount
0580	27	<a href="#">MOA</a>	M	99	1	Correction amount
0620	28	<a href="#">UNT</a>	M	1	0	Message trailer
0000	29	<a href="#">UNZ</a>	M	1	0	Interchange trailer

Tag = Segment-/Group-Name  
 Index = Segment Index Number (in Standard)  
 No. = Unique Segment-Number in Guide  
 MaxOcc = Max. Occurrence in Segment/Group

St = Status  
 EDIFACT: M=Mandatory, C=Conditional  
 Usage: R=Required, O=Optional, D=Dependent, A=Advised,  
 N=Not used

**Message structure diagram (used Segments/Groups)**

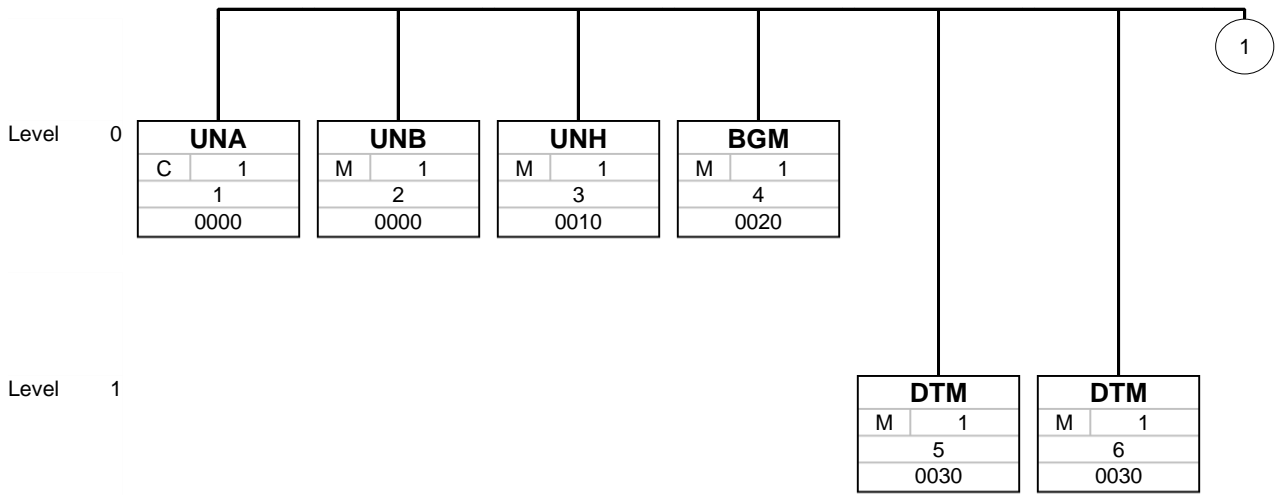

Name
St MaxOcc
No.
Index

Name = Segment-/Group-Name  
 St = Status (M=Mandatory, C=Conditional, R=Required, O=Optional, D=Dependent, A=Advised)  
 MaxOcc = Max. Occurrence of Segment/Gruppe  
 No. = Segment-Number in Guide  
 Index = Segmente-Number (in Standard)

**Message structure diagram (used Segments/Groups)**

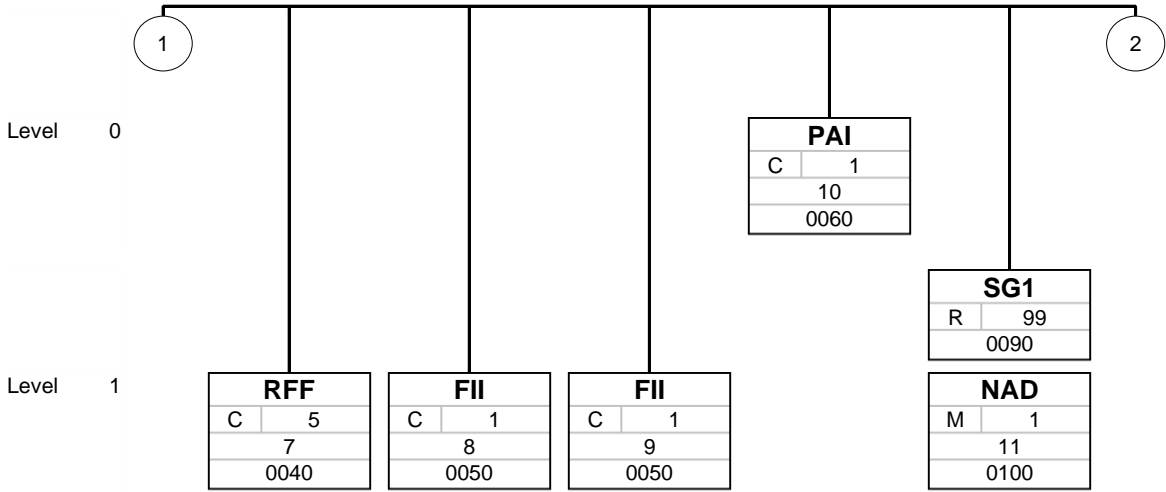

Name
St MaxOcc
No.
Index

Name = Segment-/Group-Name  
 St = Status (M=Mandatory, C=Conditional, R=Required, O=Optional, D=Dependent, A=Advised)  
 MaxOcc = Max. Occurrence of Segment/Gruppe  
 No. = Segment-Number in Guide  
 Index = Segmente-Number (in Standard)

**Message structure diagram (used Segments/Groups)**

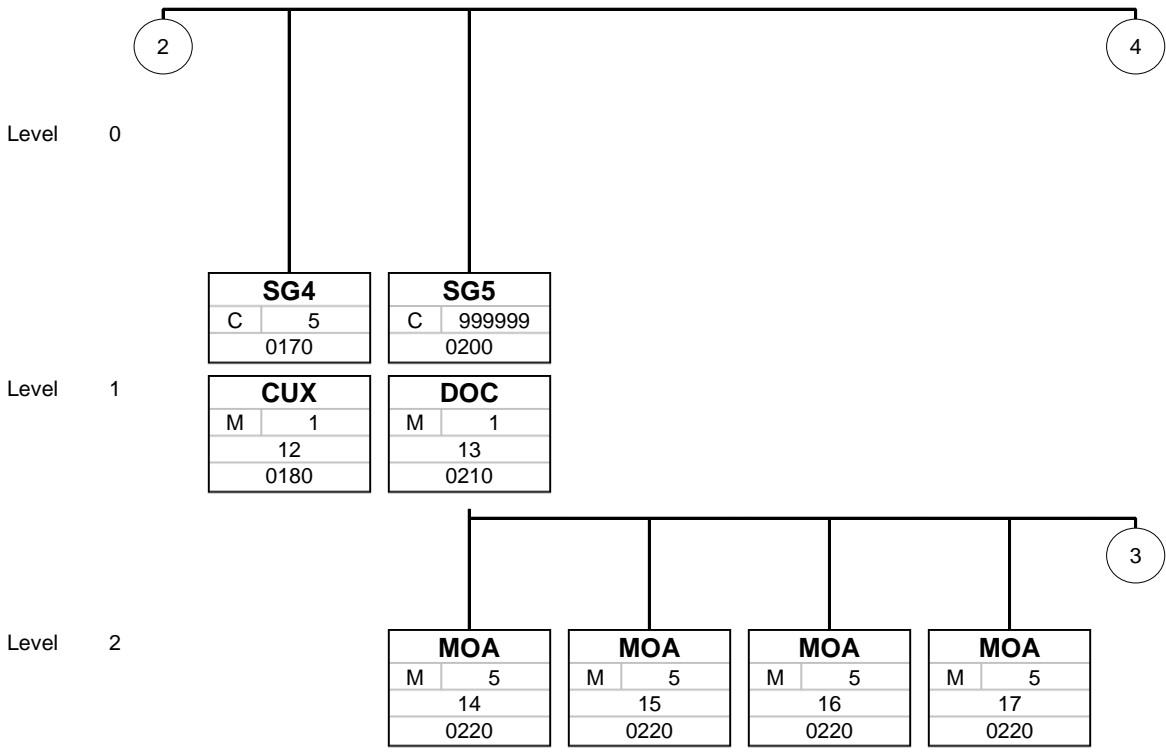

Name
St MaxOcc
No.
Index

Name = Segment-/Group-Name  
 St = Status (M=Mandatory, C=Conditional, R=Required, O=Optional, D=Dependent, A=Advised)  
 MaxOcc = Max. Occurence of Segment/Gruppe  
 No. = Segment-Number in Guide  
 Index = Segmente-Number (in Standard)

**Message structure diagram (used Segments/Groups)**

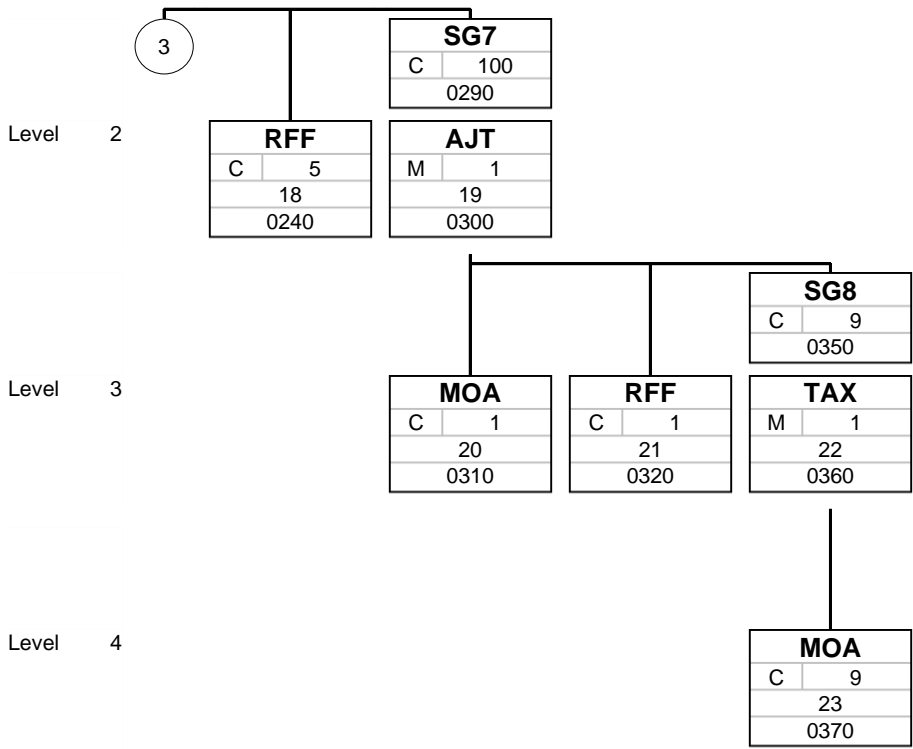

Name
St MaxOcc
No.
Index

Name = Segment-/Group-Name  
 St = Status (M=Mandatory, C=Conditional, R=Required, O=Optional, D=Dependent, A=Advised)  
 MaxOcc = Max. Occurence of Segment/Gruppe  
 No. = Segment-Number in Guide  
 Index = Segmente-Number (in Standard)

**Message structure diagram (used Segments/Groups)**

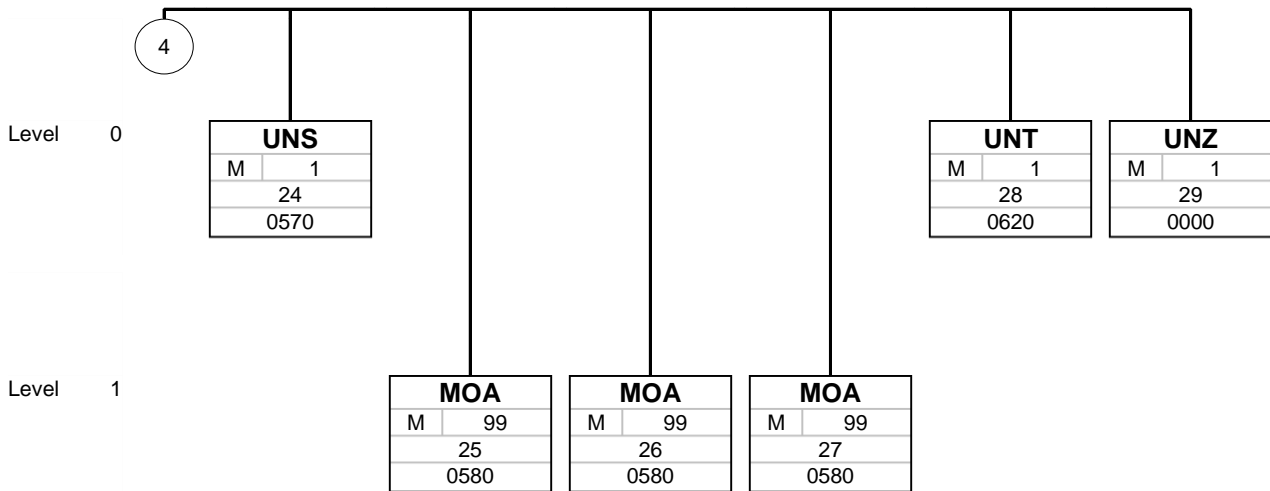

Name
St MaxOcc
No.
Index

Name = Segment-/Group-Name  
 St = Status (M=Mandatory, C=Conditional, R=Required, O=Optional, D=Dependent, A=Advised)  
 MaxOcc = Max. Occurrence of Segment/Gruppe  
 No. = Segment-Number in Guide  
 Index = Segmente-Number (in Standard)



## Segments

Index	No.	Tag	St	MaxOcc	Level	Description
0000	1	<b>UNA</b>	C	1	0	Service string advice

Standard			Implementation	
Name	Name	St Format	St Format	Usage / Remark
UNA				
UNA1	Component data element separator	M an1	M an1	: <b>Composite separator</b>
UNA2	Data element separator	M an1	M an1	+ <b>Segment separator</b>
UNA3	Decimal notation	M an1	M an1	. <b>Decimal point</b>
UNA4	Release indicator	M an1	M an1	? <b>Masking character</b>
UNA5	Reserved for future use	M an1	M an1	Space character
UNA6	Segment terminator	M an1	M an1	' <b>Segment terminator character</b>

**Remark:**

This segment defines the characters reserved for this format.  
Only the Edifact standard characters specified here apply to this format.

**Example:**

UNA:+.?'

Tag = Object-Name  
 No. = Segment-Number in Guide  
 MaxOcc = Max. Occurrence of Segment/Group  
 Index = Index-Number of Segment/Group (in Standard)

St = Status  
 EDIFACT: M=Mandatory, C=Conditional  
 Usage: R=Required, O=Optional, D=Dependent, A=Advised,  
 N=Not used

## Segments

Index No.	Tag	St	MaxOcc	Level	Description
-----------	-----	----	--------	-------	-------------

0000	2	<b>UNB</b>	M	1	0	Interchange header
------	---	------------	---	---	---	--------------------

Standard			Implementation	
Name	Name	St Format	St Format	Usage / Remark
UNB				
S001	Syntax identifier	M	M	
0001	Syntax identifier	M a4	M a4	<b>UNOC UN/ECE level C</b>
0002	Syntax version number	M n1	M n1	<b>3 Version 3</b>
S002	Interchange sender	M	M	
0004	Sender identification	M an..35	R an..35	<b>Sender identifier (GLN)</b>
0007	Partner identification code qualifier	C an..4	R an..4	<b>14 GS1 ZZZ bilaterally agreed</b>
S003	Interchange recipient	M	M	
0010	Recipient identification	M an..35	R an..35	<b>Receiver identifier (GLN)</b>
0007	Partner identification code qualifier	C an..4	R an..4	<b>14 GS1 ZZZ bilaterally agreed</b>
0014	Routing address	C an..14	C an..14	<b>Forwarding address (GLN)</b> Only if bilaterally agreed. The recipient is responsible for the forwarding.
S004	Date/time of preparation	M	M	
0017	Date of preparation	M n6	M n6	<b>Creation date of the EDIFACT file (YYMMDD)</b>
0019	Time of preparation	M n4	M n4	<b>Creation time of the EDIFACT file (HHMM)</b>
0020	Interchange control reference	M an..14	M an..14	Unique data exchange reference number (file counter). Corresponds to the specification in UNZ 0020.
S005	Recipient's reference, password	C	N	
0022	Recipient's reference/password	M an..14	N	Not used
0026	Application reference	C an..14	O an..14	<b>Name and version number of the sending system</b>
0029	Processing priority code	C a1	N	Not used
0031	Acknowledgement request	C n1	N	Not used
0032	Communications agreement ID	C an..35	R an..35	= "DCC-FURN-V1.0.1"

**Remark:**

This segment is used to uniquely identify the sender and recipient of the message.  
The actual technical participant is specified here. This may differ from the information in the NAD segments.  
Technical sender and recipient must be identifiable by a unique identification number (GLN).

In exceptional cases, other identification numbers that are not GLNs can also be used here. In these cases, the qualifier ZZZ must be used after bilateral agreement between sender and receiver.

**Example:**

UNB+UNOC:3+4399901793453:14+4041116000009:14:4139916000005+180619:0738+2356+++++DCC-FURN-V1.0.1'

The sender of the message is 4399901793453, the recipient is 4041116000009.

The message was created on 27/04/2018 at 16:30h and has the unique reference number 2356.

Tag = Object-Name  
No. = Segment-Number in Guide  
MaxOcc = Max. Occurrence of Segment/Group  
Index = Index-Number of Segment/Group (in Standard)

St = Status  
EDIFACT: M=Mandatory, C=Conditional  
Usage: R=Required, O=Optional, D=Dependent, A=Advised,  
N=Not used

## Segments

Index No.	Tag	St	MaxOcc	Level	Description
-----------	-----	----	--------	-------	-------------

**Message header**

0010	3	UNH	M	1	0	Message header
------	---	-----	---	---	---	----------------

		Standard	Implementation	
Name	Name	St Format	St Format	Usage / Remark
	UNH			
0062	Message reference number	M an..14	M an..14	
S009	Message identifier	M	M	
0065	Message type	M an..6	M an..6	<b>REMADV Remittance advice message</b>
0052	Message version number	M an..3	M an..3	<b>D Draft version/UN/EDIFACT Directory</b>
0054	Message release number	M an..3	M an..3	<b>01B Release 2001 - B</b>
0051	Controlling agency	M an..2	M an..2	<b>UN UN/CEFACT</b>
0057	Association assigned code	C an..6	R an..6	<b>EAN010 GS1 version control number (GS1 Permanent Code)</b>

**Remark:**

This segment is used to open a message document.

**Example:**

UNH+1+REMADV:D:01B:UN:EAN001'

This message is an Edifact REMADV.

Tag = Object-Name

No. = Segment-Number in Guide

MaxOcc = Max. Occurrence of Segment/Group

Index = Index-Number of Segment/Group (in Standard)

St = Status

EDIFACT: M=Mandatory, C=Conditional

Usage: R=Required, O=Optional, D=Dependent, A=Advised,

N=Not used

## Segments

Index No.	Tag	St	MaxOcc	Level	Description
-----------	-----	----	--------	-------	-------------

Message header

0020	4	<b>BGM</b>	M	1	0	Document type and document number
------	---	------------	---	---	---	-----------------------------------

			Standard	Implementation	
Name	Name	St	Format	St	Format / Usage / Remark
BGM					
C002	Document/message name	C		C	
1001	Document name code	C	an..3	R	an..3 <b>481 Remittance advice</b>
C106	Document/message identification	C		C	
1004	Document identifier	C	an..35	R	an..35 Document number
1225	Message function code	C	an..3	R	an..3 Document control indicator <b>9 Original</b>

**Remark:**

In this segment the document type and the unique document number of the document issuer are specified

**Example:**

BGM+481+ZA92832+9'

This document is a payment advice with document number RE18129.

Tag = Object-Name

No. = Segment-Number in Guide

MaxOcc = Max. Occurrence of Segment/Group

Index = Index-Number of Segment/Group (in Standard)

St = Status

EDIFACT: M=Mandatory, C=Conditional

Usage: R=Required, O=Optional, D=Dependent, A=Advised,

N=Not used

## Segments

Index No.	Tag	St	MaxOcc	Level	Description
-----------	-----	----	--------	-------	-------------

Message header

0030	5	<b>DTM</b>	M	1	1	Document date
------	---	------------	---	---	---	---------------

			Standard	Implementation	
Name	Name	St	Format	St	Format / Usage / Remark
DTM					
C507	Date/time/period	M	M	M	
2005	Date or time or period function code qualifier	M	an..3	M	an..3 Specifies the function of the date. <b>137 Document/message date/time</b>
2380	Date or time or period value	C	an..35	C	an..35
2379	Date or time or period format code	C	an..3	R	an..3 <b>102 CCYYMMDD</b>

**Remark:**

The creation date of the document.  
Must be specified with code value 137 in the message

**Example:**

DTM+137:20180619:102'

The document was created on 24/05/2018.

Tag = Object-Name  
No. = Segment-Number in Guide  
MaxOcc = Max. Occurrence of Segment/Group  
Index = Index-Number of Segment/Group (in Standard)

St = Status  
EDIFACT: M=Mandatory, C=Conditional  
Usage: R=Required, O=Optional, D=Dependent, A=Advised, N=Not used

## Segments

Index No.	Tag	St	MaxOcc	Level	Description
-----------	-----	----	--------	-------	-------------

Message header

0030 6 **DTM** M 1 1 Execution date

Standard			Implementation	
Name	Name	St Format	St Format	Usage / Remark
DTM				
C507	Date/time/period	M	M	
2005	Date or time or period function code qualifier	M an..3	M an..3	Specifies the function of the date. <b>203 Execution date/time, requested</b>
2380	Date or time or period value	C an..35	C an..35	Payment execution date
2379	Date or time or period format code	C an..3	R an..3	<b>102 CCYYMMDD</b>

**Remark:**

The execution date of the payment

**Example:**

DTM+203:20180624:102'

The payment will be executed on 24.06.2018

Tag = Object-Name  
No. = Segment-Number in Guide  
MaxOcc = Max. Occurrence of Segment/Group  
Index = Index-Number of Segment/Group (in Standard)

St = Status  
EDIFACT: M=Mandatory, C=Conditional  
Usage: R=Required, O=Optional, D=Dependent, A=Advised, N=Not used

## Segments

Index No.	Tag	St	MaxOcc	Level	Description	
0040	7	<b>RFF</b>	C	5	1	Payment instruction number

Standard			Implementation	
Name	Name	St Format	St Format	Usage / Remark
RFF				
C506	Reference	M	M	
1153	Reference code qualifier	M an..3	M an..3	<b>AEK Payment order number</b>
1154	Reference identifier	C an..70	C an..70	Payment instruction number

**Remark:**

A payment instruction can be referenced here.

**Example:**

RFF+AEK:33589'

The payment instruction number is 33589

Tag = Object-Name

No. = Segment-Number in Guide

MaxOcc = Max. Occurrence of Segment/Group

Index = Index-Number of Segment/Group (in Standard)

St = Status

EDIFACT: M=Mandatory, C=Conditional

Usage: R=Required, O=Optional, D=Dependent, A=Advised,

N=Not used

## Segments

Index	No.	Tag	St	MaxOcc	Level	Description
0050	8	<b>FII</b>	C	1	1	Credit institution of the recipient

			Standard	Implementation		
Name	Name	St	Format	St	Format	Usage / Remark
FII						
3035	Party function code qualifier	M	an..3	M	an..3	<b>RB Receiving financial institution</b>
C078	Account holder identification	C		R		
3194	Account holder identifier	C	an..35	R	an..35	<b>IBAN of the recipient</b>
3192	Account holder name	C	an..35	O	an..35	
C088	Institution identification	C		R		
3433	Institution name code	C	an..11	R	an..11	<b>BIC of the recipient</b>

### Remark:

Here you can specify to which bank account the payment will be made.

### Example:

FII+RB+DE85570400440815081500+COBADEFFXXX'

The payment instruction is made to the account DE85570400440815081500

Tag = Object-Name

No. = Segment-Number in Guide

MaxOcc = Max. Occurrence of Segment/Group

Index = Index-Number of Segment/Group (in Standard)

St = Status

EDIFACT: M=Mandatory, C=Conditional

Usage: R=Required, O=Optional, D=Dependent, A=Advised,

N=Not used



## Segments

Index No.	Tag	St	MaxOcc	Level	Description	
0050	9	<b>FII</b>	C	1	1	Credit institution of the payer

Standard			Implementation	
Name	Name	St Format	St Format	Usage / Remark
FII				
3035	Party function code qualifier	M an..3	M an..3	<b>PB Paying financial institution</b>
C078	Account holder identification	C	R	
3194	Account holder identifier	C an..35	R an..35	<b>IBAN of the recipient</b>
3192	Account holder name	C an..35	O an..35	
C088	Institution identification	C	R	
3433	Institution name code	C an..11	R an..11	<b>BIC of the recipient</b>

### Remark:

Information about the sender account of a bank transfer can be specified here.

### Example:

FII+PB+DE85130400440623000100+KSKDEEFFXXX'

The payment instruction will be made from account DE85130400440623000100

Tag = Object-Name

No. = Segment-Number in Guide

MaxOcc = Max. Occurrence of Segment/Group

Index = Index-Number of Segment/Group (in Standard)

St = Status

EDIFACT: M=Mandatory, C=Conditional

Usage: R=Required, O=Optional, D=Dependent, A=Advised,

N=Not used

## Segments

Index	No.	Tag	St	MaxOcc	Level	Description
0060	10	<b>PAI</b>	C	1	0	Payment instructions

Standard			Implementation	
Name	Name	St Format	St Format	Usage / Remark
PAI				
C534	Payment instruction details	M	M	
4439	Payment conditions code	C an..3	C an..3	<b>1 Direct payment</b>
4431	Payment guarantee means code	C an..3	C an..3	<b>20 Goods as security</b>
4461	Payment means code	C an..3	C an..3	<b>42 Payment to bank account</b>

### Remark:

Details of the payment method are given here.

### Example:

PAI+1:20:42'

Payment is made by bank transfer

Tag = Object-Name

No. = Segment-Number in Guide

MaxOcc = Max. Occurrence of Segment/Group

Index = Index-Number of Segment/Group (in Standard)

St = Status

EDIFACT: M=Mandatory, C=Conditional

Usage: R=Required, O=Optional, D=Dependent, A=Advised,

N=Not used

## Segments

Index No.	Tag	St	MaxOcc	Level	Description
0090	SG1	R	99	1	<b>Names and addresses of the parties involved</b>
<b>Message header</b>					
0100 11	NAD	M	1	1	<b>Name and address</b>

Standard			Implementation	
Name	Name	St Format	St Format	Usage / Remark
NAD				
3035	Party function code qualifier	M an..3	M an..3	<b>PE Payee</b> <b>PR Payer</b> <b>SU Supplier</b> <b>BY Buyer</b>
C082	Party identification details	C	A	
3039	Party identifier	M an..35	M an..35	GLN or other unique identification number of the party involved.
1131	Code list identification code	C an..17	N	Not used
3055	Code list responsible agency code	C an..3	R an..3	<b>9 GS1</b> <b>91 Assigned by supplier or supplier's agent</b> <b>92 Assigned by buyer or buyer's agent</b>
C058	Name and address	C	N	
3124	Name and address description	M an..35	N	Not used
C080	Party name	C	C	
3036	Party name	M an..35	M an..35	<b>Name</b> For companies : company name For individuals: firstname lastname
3036	Party name	C an..35	O an..35	For companies: company name continuation For individuals: blank
3036	Party name	C an..35	O an..35	For companies: blank For individuals: firstname
3036	Party name	C an..35	O an..35	For companies: blank For individuals: lastname
C059	Street	C	C	
3042	Street and number or post office box identifier	M an..35	M an..35	<b>Street and house number</b>
3042	Street and number or post office box identifier	C an..35	O an..35	
3042	Street and number or post office box identifier	C an..35	O an..35	
3042	Street and number or post office box identifier	C an..35	O an..35	
3164	City name	C an..35	C an..35	<b>Location</b>
C819	Country sub-entity details	C	N	
3229	Country sub-entity name code	C an..9	N	Not used
3251	Postal identification code	C an..17	C an..17	<b>Postal code</b>
3207	Country name code	C an..3	C an..3	<b>Country code (2 digits, ISO)</b> e.g.: DE , AT ...

**Remark:**

Address information:

GLN, name and address of the companies involved

The use of GLN numbers is recommended here. In exceptional cases other codes can be used here bilaterally agreed, then the code 91 or 92 must be indicated in field 3055.

**Example:**

NAD+BY+8765432123456::9'

The GLN of the buyer is 8765432123456

Tag = Object-Name  
No. = Segment-Number in Guide  
MaxOcc = Max. Occurence of Segment/Group  
Index = Index-Number of Segment/Group (in Standard)

St = Status  
EDIFACT: M=Mandatory, C=Conditional  
Usage: R=Required, O=Optional, D=Dependent, A=Advised, N=Not used

## Segments

Tag = Object-Name

No. = Segment-Number in Guide

MaxOcc = Max. Occurrence of Segment/Group

Index = Index-Number of Segment/Group (in Standard)

St = Status

EDIFACT: M=Mandatory, C=Conditional

Usage: R=Required, O=Optional, D=Dependent, A=Advised,

N=Not used

## Segments

Index No.	Tag	St	MaxOcc	Level	Description
0170	<b>SG4</b>	C	5	1	<b>Currency</b>
0180 12	<b>CUX</b>	M	1	1	<b>Currencies</b>

Standard			Implementation	
Name	Name	St Format	St Format	Usage / Remark
CUX				
C504	Currency details	C	C	
6347	Currency usage code qualifier	M an..3	M an..3	<b>2 Reference currency</b>
6345	Currency identification code	C an..3	C an..3	
6343	Currency type code qualifier	C an..3	C an..3	<b>11 Payment currency</b>

### Remark:

Currency of the regulated amounts

### Example:

CUX+2:EUR:11'

The payment will be made in EURO

Tag = Object-Name

No. = Segment-Number in Guide

MaxOcc = Max. Occurrence of Segment/Group

Index = Index-Number of Segment/Group (in Standard)

St = Status

EDIFACT: M=Mandatory, C=Conditional

Usage: R=Required, O=Optional, D=Dependent, A=Advised,

N=Not used

## Segments

Index No.	Tag	St	MaxOcc	Level	Description
0200	<b>SG5</b>	C	999999	1	Documents
0210 13	<b>DOC</b>	M	1	1	Document/message details

Standard			Implementation	
Name	Name	St Format	St Format	Usage / Remark
DOC				
C002	Document/message name	M	M	
1001	Document name code	C an..3	C an..3	<b>380 Commercial invoice</b> <b>84 Debit note related to financial adjustments</b>
C503	Document/message details	C	C	
1004	Document identifier	C an..35	C an..35	

### Remark:

The details of the regulating documents are given here.  
 A separate segment group must be created for each document included in the settlement amount.

### Example:

DOC+380+RE18129'

This payment advice settles the invoice RE18129

Tag = Object-Name  
 No. = Segment-Number in Guide  
 MaxOcc = Max. Occurrence of Segment/Group  
 Index = Index-Number of Segment/Group (in Standard)

St = Status  
 EDIFACT: M=Mandatory, C=Conditional  
 Usage: R=Required, O=Optional, D=Dependent, A=Advised,  
 N=Not used

**Segments**

Index No.	Tag	St	MaxOcc	Level	Description
0200	<b>SG5</b>	C	999999	1	<b>Documents</b>
0220 14	<b>MOA</b>	M	5	2	<b>Invoice amount</b>

Standard			Implementation	
Name	Name	St Format	St Format	Usage / Remark
MOA				
C516	Monetary amount	M	M	
5025	Monetary amount type code qualifier	M an..3	M an..3	<b>77 Invoice amount</b>
5004	Monetary amount	C n..35	C n..35	

**Remark:**

This MOA segment shows the final amount of the document as reported by the vendor. The amount must be indicated including VAT.

**Example:**

MOA+77:822.88'

The invoice amount shown on the voucher is EUR 822.88

Tag = Object-Name  
 No. = Segment-Number in Guide  
 MaxOcc = Max. Occurrence of Segment/Group  
 Index = Index-Number of Segment/Group (in Standard)

St = Status  
 EDIFACT: M=Mandatory, C=Conditional  
 Usage: R=Required, O=Optional, D=Dependent, A=Advised,  
 N=Not used

## Segments

Index No.	Tag	St	MaxOcc	Level	Description
0200	<b>SG5</b>	C	999999	1	<b>Documents</b>
0220 15	<b>MOA</b>	M	5	2	<b>Regulation amount</b>

Standard			Implementation	
Name	Name	St Format	St Format	Usage / Remark
MOA				
C516	Monetary amount	M	M	
5025	Monetary amount type code qualifier	M an..3	M an..3	<b>11 Amount paid</b>
5004	Monetary amount	C n..35	C n..35	

### Remark:

This MOA segment shows the regulated amount of the document.  
The amount must be indicated including VAT.

### Example:

MOA+11:798.19'

The regulated amount is 798.19 EUR

Tag = Object-Name

No. = Segment-Number in Guide

MaxOcc = Max. Occurrence of Segment/Group

Index = Index-Number of Segment/Group (in Standard)

St = Status

EDIFACT: M=Mandatory, C=Conditional

Usage: R=Required, O=Optional, D=Dependent, A=Advised,

N=Not used



## Segments

Index No.	Tag	St	MaxOcc	Level	Description
0200	<b>SG5</b>	C	999999	1	<b>Documents</b>
0220 16	<b>MOA</b>	M	5	2	<b>Tax amount</b>

Standard			Implementation	
Name	Name	St Format	St Format	Usage / Remark
MOA				
C516	Monetary amount	M	M	
5025	Monetary amount type code qualifier	M an..3	M an..3	<b>124 Tax amount</b>
5004	Monetary amount	C n..35	C n..35	

### Remark:

This MOA segment shows the tax portion of the regulated amount.  
 If the regulated document is subject to different tax rates, the total of all tax shares must be indicated here.

### Example:

MOA+124:127.44'

The tax portion of the receipt is EUR 127.44

Tag = Object-Name  
 No. = Segment-Number in Guide  
 MaxOcc = Max. Occurrence of Segment/Group  
 Index = Index-Number of Segment/Group (in Standard)

St = Status  
 EDIFACT: M=Mandatory, C=Conditional  
 Usage: R=Required, O=Optional, D=Dependent, A=Advised,  
 N=Not used

**Segments**

Index No.	Tag	St	MaxOcc	Level	Description
0200	<b>SG5</b>	C	999999	1	<b>Documents</b>
0220 17	<b>MOA</b>	M	5	2	<b>Correction amount</b>

		Standard		Implementation	
Name	Name	St	Format	St	Format / Usage / Remark
MOA					
C516	Monetary amount	M		M	
5025	Monetary amount type code qualifier	M	an..3	M	an..3 <b>165 Adjustment amount</b>
5004	Monetary amount	C	n..35	C	n..35

**Remark:**

This MOA segment shows the adjustment amount of the document.  
 This must be indicated if corrections have been made.  
 The adjustment amount is calculated as the difference between the total amount (MOA+77) and the regulated amount (MOA+11).  
 The amount must be indicated including VAT.

The reasons for the correction(s) shall be provided in the AJT segment below.  
 The adjustment amount is therefore equal to the sum of all AJT MOAs at the document level.

If corrections are made that increase the payment amount (as opposed to cash discount or rebate deductions) the correction amount must be explicitly indicated with a minus sign.

**Example:**

MOA+165:24.68'  
 The amount of the correction is EUR 24.68.

## Segments

Index No.	Tag	St	MaxOcc	Level	Description
0200	<b>SG5</b>	C	999999	1	<b>Documents</b>
0240 18	<b>RFF</b>	C	5	2	<b>Reference</b>

Standard			Implementation	
Name	Name	St Format	St Format	Usage / Remark
RFF				
C506	Reference	M	M	
1153	Reference code qualifier	M an..3	M an..3	<b>ACE Related document number</b>
1154	Reference identifier	C an..70	C an..70	

### Remark:

Other vouchers/documents can be referenced here.

### Example:

RFF+ACE:8799'

The document references the document number 8799

Tag = Object-Name  
 No. = Segment-Number in Guide  
 MaxOcc = Max. Occurrence of Segment/Group  
 Index = Index-Number of Segment/Group (in Standard)

St = Status  
 EDIFACT: M=Mandatory, C=Conditional  
 Usage: R=Required, O=Optional, D=Dependent, A=Advised,  
 N=Not used

## Segments

Index No.	Tag	St	MaxOcc	Level	Description
0200	<b>SG5</b>	C	999999	1	<b>Documents</b>
0290	<b>SG7</b>	C	100	2	<b>Amount corrections</b>
0300 19	<b>AJT</b>	M	1	2	<b>Adjustment details</b>

		Standard	Implementation	
Name	Name	St Format	St Format	Usage / Remark
AJT				
4465	Adjustment reason description code	M an..3	M an..3	<b>1 Agreed settlement</b> <b>7 Payment on account</b> <b>17 Transport damage</b> <b>19 Trade discount</b> <b>21 Advertising costs</b> <b>38 Deducted bonus</b> <b>68 Early payment allowance adjustment</b>

**Remark:**

Reasons for correction of the document amount can be specified in this segment.

**Example:**

AJT+68'

The reason for the amount correction is a cash discount deduction

Tag = Object-Name  
 No. = Segment-Number in Guide  
 MaxOcc = Max. Occurrence of Segment/Group  
 Index = Index-Number of Segment/Group (in Standard)

St = Status  
 EDIFACT: M=Mandatory, C=Conditional  
 Usage: R=Required, O=Optional, D=Dependent, A=Advised, N=Not used

## Segments

Index No.	Tag	St	MaxOcc	Level	Description
0200	<b>SG5</b>	C	999999	1	<b>Documents</b>
0290	<b>SG7</b>	C	100	2	<b>Amount corrections</b>
0310 20	<b>MOA</b>	C	1	3	<b>Correction amount</b>

		Standard	Implementation	
Name	Name	St Format	St Format	Usage / Remark
MOA				
C516	Monetary amount	M	M	
5025	Monetary amount type code qualifier	M an..3	M an..3	<b>165 Adjustment amount</b>
5004	Monetary amount	C n..35	C n..35	

### Remark:

The correction amount including VAT is specified here.

### Example:

MOA+165:24.68'

The correction amount is EUR 24.68

AJT+68'

MOA+165:13.44'

A discount of 13.44 EUR was deducted.

AJT+19'

MOA+165:120'

A trade discount of 120.00 EUR was deducted.

Tag = Object-Name  
 No. = Segment-Number in Guide  
 MaxOcc = Max. Occurrence of Segment/Group  
 Index = Index-Number of Segment/Group (in Standard)

St = Status  
 EDIFACT: M=Mandatory, C=Conditional  
 Usage: R=Required, O=Optional, D=Dependent, A=Advised,  
 N=Not used

## Segments

Index No.	Tag	St	MaxOcc	Level	Description
0200	<b>SG5</b>	C	999999	1	<b>Documents</b>
0290	<b>SG7</b>	C	100	2	<b>Amount corrections</b>
0320 21	<b>RFF</b>	C	1	3	<b>Reference</b>

Standard			Implementation	
Name	Name	St Format	St Format	Usage / Remark
RFF				
C506	Reference	M	M	
1153	Reference code qualifier	M an..3	M an..3	<b>AGA Agreement to pay number</b>
1154	Reference identifier	C an..70	C an..70	

**Remark:**

**Example:**

RFF+AGA:V1246174'

The adjustment is made according to the payment agreement V1246174

Tag = Object-Name  
 No. = Segment-Number in Guide  
 MaxOcc = Max. Occurrence of Segment/Group  
 Index = Index-Number of Segment/Group (in Standard)

St = Status  
 EDIFACT: M=Mandatory, C=Conditional  
 Usage: R=Required, O=Optional, D=Dependent, A=Advised,  
 N=Not used

## Segments

Index No.	Tag	St	MaxOcc	Level	Description
0200	<b>SG5</b>	C	999999	1	<b>Documents</b>
0290	<b>SG7</b>	C	100	2	<b>Amount corrections</b>
0350	<b>SG8</b>	C	9	3	<b>Tax</b>
0360 22	<b>TAX</b>	M	1	3	<b>Duty/tax/fee details</b>

Standard			Implementation	
Name	Name	St Format	St Format	Usage / Remark
TAX				
5283	Duty or tax or fee function code qualifier	M an..3	M an..3	<b>7 Tax</b>
C241	Duty/tax/fee type	C	C	
5153	Duty or tax or fee type name code	C an..3	C an..3	<b>VAT Value added tax</b>
C533	Duty/tax/fee account detail	C	N	
5289	Duty or tax or fee account code	M an..6	N	Not used
5286	Duty or tax or fee assessment basis value	C an..15	N	Not used
C243	Duty/tax/fee detail	C	C	
5279	Duty or tax or fee rate code	C an..7	N	Not used
1131	Code list identification code	C an..17	N	Not used
3055	Code list responsible agency code	C an..3	N	Not used
5278	Duty or tax or fee rate	C an..17	C an..17	Tax rate
5305	Duty or tax or fee category code	C an..3	C an..3	<b>E Exempt from tax S Standard rate O Services outside scope of tax</b>

**Remark:**

This is where the tax information is specified.

If more than one tax rate is required, create a separate segment group for each tax rate.

In the case of tax-exempt or non-taxable sales, the value zero must be explicitly stated here.

If more than one tax rate is required, create a separate segment group for each tax rate.

In the case of tax-exempt or non-taxable sales, the value zero must be explicitly stated here.

**Example:**

TAX+7+VAT+++:::7+S'

The following amounts are for the 7% VAT portion of the regulated receipt.

Tag = Object-Name  
 No. = Segment-Number in Guide  
 MaxOcc = Max. Occurrence of Segment/Group  
 Index = Index-Number of Segment/Group (in Standard)

St = Status  
 EDIFACT: M=Mandatory, C=Conditional  
 Usage: R=Required, O=Optional, D=Dependent, A=Advised,  
 N=Not used

## Segments

Index No.	Tag	St	MaxOcc	Level	Description
0200	<b>SG5</b>	C	999999	1	<b>Documents</b>
0290	<b>SG7</b>	C	100	2	<b>Amount corrections</b>
0350	<b>SG8</b>	C	9	3	<b>Tax</b>
0370 23	<b>MOA</b>	C	9	4	<b>Monetary amount</b>

Standard			Implementation	
Name	Name	St Format	St Format	Usage / Remark
MOA				
C516	Monetary amount	M	M	
5025	Monetary amount type code qualifier	M an..3	M an..3	<b>165 Adjustment amount</b> <b>124 Tax amount</b>
5004	Monetary amount	C n..35	C n..35	

**Remark:**

The amounts that refer to a specific tax rate are shown here.

In MOA+165, correction amount incl. VAT is specified.

In MOA+124 the tax portion included in the adjustment amount.

**Example:**

MOA+165:9'

The correction amount incl. 7% VAT is 9.00 EUR

Tag = Object-Name  
No. = Segment-Number in Guide  
MaxOcc = Max. Occurrence of Segment/Group  
Index = Index-Number of Segment/Group (in Standard)

St = Status  
EDIFACT: M=Mandatory, C=Conditional  
Usage: R=Required, O=Optional, D=Dependent, A=Advised,  
N=Not used



## Segments

Index	No.	Tag	St	MaxOcc	Level	Description
0570	24	<b>UNS</b>	M	1	0	Section control

Standard			Implementation	
Name	Name	St Format	St Format	Usage / Remark
UNS				
0081	Section identification	M a1	M a1	<b>S Detail/summary section separation</b>

### Remark:

### Example:

UNS+S'

Tag = Object-Name  
 No. = Segment-Number in Guide  
 MaxOcc = Max. Occurrence of Segment/Group  
 Index = Index-Number of Segment/Group (in Standard)

St = Status  
 EDIFACT: M=Mandatory, C=Conditional  
 Usage: R=Required, O=Optional, D=Dependent, A=Advised,  
 N=Not used

## Segments

Index No.	Tag	St	MaxOcc	Level	Description
0580 25	<b>MOA</b>	M	99	1	Total amount

Standard			Implementation	
Name	Name	St Format	St Format	Usage / Remark
MOA				
C516	Monetary amount	M	M	
5025	Monetary amount type code qualifier	M an..3	M an..3	<b>9 Amount due/amount payable</b>
5004	Monetary amount	C n..35	C n..35	

**Remark:**

This segment contains the sum of all MOA+77 from the position part

**Example:**

MOA+9: 822.88'

The total amount is 822,88 EUR

Tag = Object-Name  
 No. = Segment-Number in Guide  
 MaxOcc = Max. Occurrence of Segment/Group  
 Index = Index-Number of Segment/Group (in Standard)

St = Status  
 EDIFACT: M=Mandatory, C=Conditional  
 Usage: R=Required, O=Optional, D=Dependent, A=Advised,  
 N=Not used

## Segments

Index No.	Tag	St	MaxOcc	Level	Description
0580 26	<b>MOA</b>	M	99	1	Regulated amount

Standard			Implementation	
Name	Name	St Format	St Format	Usage / Remark
MOA				
C516	Monetary amount	M	M	
5025	Monetary amount type code qualifier	M an..3	M an..3	<b>12 Amount remitted</b>
5004	Monetary amount	C n..35	C n..35	

### Remark:

This segment contains the sum of all MOA+11 from the position part

### Example:

MOA+12: 798.19'

The regulated amount is 798,19 EUR

Tag = Object-Name  
 No. = Segment-Number in Guide  
 MaxOcc = Max. Occurrence of Segment/Group  
 Index = Index-Number of Segment/Group (in Standard)

St = Status  
 EDIFACT: M=Mandatory, C=Conditional  
 Usage: R=Required, O=Optional, D=Dependent, A=Advised,  
 N=Not used

## Segments

Index No.	Tag	St	MaxOcc	Level	Description
0580 27	<b>MOA</b>	M	99	1	Correction amount

		Standard		Implementation	
Name	Name	St Format	St Format	Usage / Remark	
MOA					
C516	Monetary amount	M	M		
5025	Monetary amount type code qualifier	M an..3	M an..3	<b>165</b>	<b>Adjustment amount</b>
5004	Monetary amount	C n..35	C n..35		

**Remark:**

This segment contains the sum of all MOA+165 from the position part

**Example:**

MOA+165: 24.68'

The amount of the correction is 24.68 EUR

Tag = Object-Name  
 No. = Segment-Number in Guide  
 MaxOcc = Max. Occurrence of Segment/Group  
 Index = Index-Number of Segment/Group (in Standard)

St = Status  
 EDIFACT: M=Mandatory, C=Conditional  
 Usage: R=Required, O=Optional, D=Dependent, A=Advised,  
 N=Not used

## Segments

Index No.	Tag	St	MaxOcc	Level	Description
0620 28	<b>UNT</b>	M	1	0	Message trailer

Standard			Implementation	
Name	Name	St Format	St Format	Usage / Remark
UNT				
0074	Number of segments in the message	M n..6	M n..6	
0062	Message reference number	M an..14	M an..14	Unique message reference of the sender. Identical to DE 0062 in UNH.

### Remark:

Segment counter

### Example:

UNT+38+1'

The document consists of 38 segments

Tag = Object-Name

No. = Segment-Number in Guide

MaxOcc = Max. Occurrence of Segment/Group

Index = Index-Number of Segment/Group (in Standard)

St = Status

EDIFACT: M=Mandatory, C=Conditional

Usage: R=Required, O=Optional, D=Dependent, A=Advised,

N=Not used

## Segments

Index	No.	Tag	St	MaxOcc	Level	Description
0000	29	<b>UNZ</b>	M	1	0	Interchange trailer

Standard			Implementation	
Name	Name	St Format	St Format	Usage / Remark
UNZ				
0036	Interchange control count	M n..6	M n..6	
0020	Interchange control reference	M an..14	M an..14	Unique data exchange reference number (file counter). Corresponds to the specification in UNB 0020.

### Remark:

### Example:

UNZ+1+2356'

The message contains 1 document.

Tag = Object-Name  
 No. = Segment-Number in Guide  
 MaxOcc = Max. Occurrence of Segment/Group  
 Index = Index-Number of Segment/Group (in Standard)

St = Status  
 EDIFACT: M=Mandatory, C=Conditional  
 Usage: R=Required, O=Optional, D=Dependent, A=Advised,  
 N=Not used

## Example

No.	Name	Example
1	UNA	UNA:+. ? '
2	UNB	UNB+UNOC:3+4399901793453:14+4041116000009:14:4139916000005+180619:0738+2356++++DCC-FURN-V1.0.1' The sender of the message is 4399901793453, the recipient is 4041116000009. The message was created on 27/04/2018 at 16:30h and has the unique reference number 2356.
<b>Message header</b>		
3	UNH	UNH+1+REMADV:D:01B:UN:EAN001' This message is an Edifact REMADV.
4	BGM	BGM+481+ZA92832+9' This document is a payment advice with document number RE18129.
5	DTM	DTM+137:20180619:102' The document was created on 24/05/2018.
6	DTM	DTM+203:20180624:102' The payment will be executed on 24.06.2018
7	RFF	RFF+AEK:33589' The payment instruction number is 33589
8	FII	FII+RB+DE85570400440815081500+COBADEFFXXX' The payment instruction is made to the account DE85570400440815081500
9	FII	FII+PB+DE85130400440623000100+KSKDEFFXXX' The payment instruction will be made from account DE85130400440623000100
10	PAI	PAI+1:20:42' Payment is made by bank transfer
<b>SG1</b>		
11	NAD	NAD+BY+8765432123456::9' The GLN of the buyer is 8765432123456
<b>SG4</b>		
12	CUX	CUX+2:EUR:11' The payment will be made in EURO
<b>SG5</b>		
13	DOC	DOC+380+RE18129' This payment advice settles the invoice RE18129
14	MOA	MOA+77:822.88' The invoice amount shown on the voucher is EUR 822.88
15	MOA	MOA+11:798.19' The regulated amount is 798.19 EUR
16	MOA	MOA+124:127.44' The tax portion of the receipt is EUR 127.44
17	MOA	MOA+165:24.68' The amount of the correction is EUR 24.68.
18	RFF	RFF+ACE:8799' The document references the document number 8799
<b>SG7</b>		
19	AJT	AJT+68' The reason for the amount correction is a cash discount deduction

No. = Segment-Number in Guide

## Example

No.	Name	Example
20	<b>MOA</b>	<b>MOA+165:24.68'</b> The correction amount is EUR 24.68  <b>AJT+68'</b> <b>MOA+165:13.44'</b> A discount of 13.44 EUR was deducted.  <b>AJT+19'</b> <b>MOA+165:120'</b> A trade discount of 120.00 EUR was deducted.
21	<b>RFF</b>	<b>RFF+AGA:V1246174'</b> The adjustment is made according to the payment agreement V1246174
	<b>SG8</b>	
22	<b>TAX</b>	<b>TAX+7+VAT+++:::7+S'</b> The following amounts are for the 7% VAT portion of the regulated receipt.
23	<b>MOA</b>	<b>MOA+165:9'</b> The correction amount incl. 7% VAT is 9.00 EUR
24	<b>UNS</b>	<b>UNS+S'</b>
25	<b>MOA</b>	<b>MOA+9:822.88'</b> The total amount is 822,88 EUR
26	<b>MOA</b>	<b>MOA+12:798.19'</b> The regulated amount is 798,19 EUR
27	<b>MOA</b>	<b>MOA+165:24.68'</b> The amount of the correction is 24.68 EUR
28	<b>UNT</b>	<b>UNT+38+1'</b> The document consists of 38 segments
29	<b>UNZ</b>	<b>UNZ+1+2356'</b> The message contains 1 document.

No. = Segment-Number in Guide